



Sri Chaitanya
Educational Institutions

Infinity
Learn



SRI CHAITANYA NATION'S 1ST CHOICE FOR IIT-JEE SUCCESS

5 STUDENTS IN TOP 10 IN JEE-ADVANCED 2024 OPEN CATEGORY



RAGHAV SHARMA
Ht. No. 242053073*

RHYTHM KEDIA
Ht. No. 247025176*

P KUSHAL KUMAR
Ht. No. 246150349

RAJDEEP MISHRA
Ht. No. 241016176*

DHRUVIN H DOSHI
Ht. No. 241108162

A SIDHVIK SUHAS
Ht. No. 246118101

HIGHLIGHTS

BELOW
100

ALL INDIA OPEN
CATEGORY RANKS

30

BELOW
500

ALL INDIA OPEN
CATEGORY RANKS

122

BELOW
1000

ALL INDIA OPEN
CATEGORY RANKS

203

BELOW
100

ALL INDIA CATEGORY
RANKS COUNT

146

BELOW
1000

ALL INDIA CATEGORY
RANKS COUNT

721

NUMBER OF
QUALIFIED
RANKS

4187+

Scan QR Code for
Admissions



JEE MAIN (JAN) 2025 - SHIFT 1

28-01-2025



Sri Chaitanya IIT Academy., India.

A.P, TELANGANA, KARNATAKA, TAMILNADU, MAHARASHTRA, DELHI, RANCHI

A right Choice for the Real Aspirant

ICON Central Office – Madhapur – Hyderabad

2025_Jee-Main_28-Jan-2025_Shift-01

MATHEMATICS

Max Marks: 100

(SINGLE CORRECT ANSWER TYPE)

This section contains 20 multiple choice questions. Each question has 4 options (1), (2), (3) and (4) for its answer, out of which ONLY ONE option can be correct.

Marking scheme: +4 for correct answer, 0 if not attempted and -1 in all other cases.

01. let the equation of the circle, which touches x-axis at the point(a, 0), $a > 0$ and cuts off an intercept length b on y-axis be $x^2 + y^2 - \alpha x + \beta y + \gamma = 0$. If the circle lies below x-axis, then the ordered pair $(2a, b^2)$ is equal to

- 1) $(\alpha, \beta^2 - 4\gamma)$ 2) $(\gamma, \beta^2 - 4\alpha)$ 3) $(\alpha, \beta^2 + 4\gamma)$ 4) $(\gamma, \beta^2 + 4\alpha)$

Key: 1

Sol: Radius, $r = \sqrt{a^2 + \frac{b^2}{4}}$

The eq.of circle is

$$(x-a)^2 + (y-r)^2 = r^2$$

$$\Rightarrow x^2 + a^2 - 2ax + y^2 + r^2 - 2ry = r^2 \quad \Rightarrow x^2 + y^2 - 2ax - 2ry + a^2 = 0$$

$$\alpha = 2a, \beta = 2r, \gamma = a^2$$

$$\beta^2 = 4r^2 = 4a^2 + b^2 \Rightarrow b^2 = \beta^2 - 4\alpha$$

$$(2a, b^2) = (\alpha, \beta^2 - 4\gamma)$$

2. The relation $R = \{(x, y) : x, y \in z \text{ and } x+y \text{ is even}\}$ is:

- 1) Symmetric and transitive but not reflexive
- 2) an equivalence relation
- 3) reflexive and symmetric but not transitive
- 4) reflexive and transitive but not symmetric

Key: 2

Sol: i) $x+x=2x$ is even

ii) if $x+y$ is even then $y+x$ is even

iii) $x+y$ is even & $y+z$ is even $\Rightarrow x+z$ is even

The relation is an equivalence relation

3. If $f(x) = \frac{2^x}{2^x + \sqrt{2}}$, $x \in R$ then $\sum_{k=1}^{81} f\left(\frac{k}{82}\right)$ is equal to

- 1) 82 2) $\frac{81}{2}$ 3) 41 4) $81\sqrt{2}$

Key: 2

Sol: $f(x) = \frac{2^x}{2^x + \sqrt{2}} \Rightarrow f(x) + f(1-x) = 1$

$$\therefore f\left(\frac{1}{82}\right) + f\left(\frac{81}{82}\right) = 1$$

$$\therefore f\left(\frac{2}{82}\right) + f\left(\frac{80}{82}\right) = 1$$

.....so on

$$\therefore \sum_{k=1}^{81} f\left(\frac{k}{82}\right) = 1 + 1 + 1 + \dots \dots 40 \text{ times} + f\left(\frac{41}{82}\right)$$

$$= 40 + f\left(\frac{1}{2}\right) = 40 + \frac{1}{2} = \frac{81}{2}$$

4. Two number k_1 and k_2 are randomly chosen from the set to natural numbers. Then, the probability that the value of $i^{k_1} + i^{k_2}$, ($i = \sqrt{-1}$) is non-zero, equals

- 1) $\frac{2}{3}$ 2) $\frac{3}{4}$ 3) $\frac{1}{2}$ 4) $\frac{1}{4}$

Key: 2

Sol: $n(S) = 4 \times 4 = 16$ [selection of k_1, k_2 from $-1, 1, -i, i$]

$$n(\bar{A}) = \{(1, -1), (-1, 1), (i, -i), (-i, i)\} \quad [i^{k_1} + i^{k_2} = 0]$$

$$n(A) = 16 - 4 = 12$$

$$P = \frac{12}{16} = \frac{3}{4}$$

5. let T_r be the r^{th} term of an A.P. . If for some m , $T_m = \frac{1}{25}$, $T_{25} = \frac{1}{20}$, and $20 \sum_{r=1}^{25} T_r = 13$, then

$5m \sum_{r=m}^{2m} T_r$ is equal to

- 1) 112 2) 98 3) 142 4) 126

Key: 4

Sol: $T_m = a + (m-1)d = \frac{1}{25} \dots \dots \dots (1)$

$T_{25} = a + 24d = \frac{1}{20} \dots \dots \dots (2)$

$20 \cdot \sum_{r=1}^{25} T_r = 13 \Rightarrow 20 \cdot \frac{25}{2} (2a + 24d) = 13 \Rightarrow 250 \left(a + \frac{1}{20} \right) = 13 \Rightarrow a = \frac{1}{500}$

(2) $\Rightarrow d = \frac{1}{500}$

(1) $\Rightarrow m = 20$

$\therefore 5m \sum_{r=m}^{2m} T_r = 100 \sum_{r=20}^{40} T_r = 126$

6. $\cos \left(\sin^{-1} \frac{3}{5} + \sin^{-1} \frac{5}{13} + \sin^{-1} \frac{33}{65} \right)$ is equal to

- 1) 1 2) 0 3) $\frac{33}{65}$ 4) $\frac{32}{65}$

Key: 2

Sol: $\cos \left(\sin^{-1} \frac{3}{5} + \sin^{-1} \frac{5}{13} + \sin^{-1} \frac{33}{65} \right)$

$= \cos \left(\sin^{-1} \frac{3}{5} + \sin^{-1} \left[\frac{5}{13} \sqrt{\frac{1-33^2}{65^2}} + \frac{33}{65} \sqrt{1-\frac{5^2}{13^2}} \right] \right)$

$= \cos \left(\sin^{-1} \frac{3}{5} + \sin^{-1} \frac{4}{5} \right)$

$= \cos \left(\sin^{-1} \frac{3}{5} + \cos^{-1} \frac{3}{5} \right) = \cos \left(\frac{\pi}{2} \right) = 0$

7. If the image of the point $(4,4,3)$ in the line $\frac{x-1}{2} = \frac{y-2}{1} = \frac{z-1}{3}$ is (α, β, γ) , then $\alpha + \beta + \gamma = ?$
- 1) 8 2) 7 3) 12 4) 9

Key: 4

Sol:

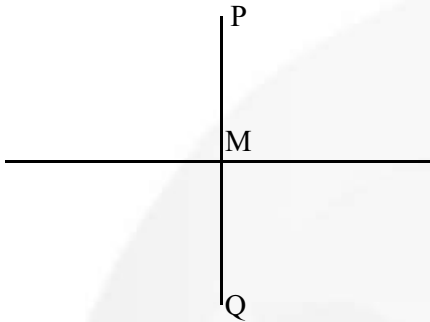

$$M = (2r+1, r+2, 3r+1)$$

(Dr's of \overline{PQ}). (Dr's of line) = 0

$$(2r-3, r-2, 3r-2) \cdot (2, 1, 3) = 0 \quad \Rightarrow r = 1$$

$$Q = 2M - P = (2, 2, 5) \quad \alpha + \beta + \gamma = 9$$

8. The number of different 5 digit numbers greater than 50000 that can be formed using the digits 0,1,2,3,4,5,6,7 such that the sum of their first and last digits should not be more than 8 is
- 1) 5720 2) 4608 3) 4607 4) 5719

Key: 3

Sol:

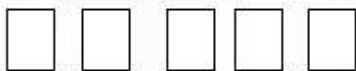

Ordered pairs first and last digits as per given condition : $(5,0), (5,1), (5,3), (6,0), (6,1), (6,2), (7,0), (7,1) = 9$ ordered pairs

Number of numbers thus formed

$$= 9 \times 8 \times 8 \times 8 = 4608$$

Among which one number will be 50000

$$\therefore \text{Required number of numbers} = 4608 - 1 = 4607$$

9. Let $n_{C_{r-1}}=28$, $n_{C_r}=56$ and $n_{C_{r+1}}=70$, let A ($4\cos t$, $4\sin t$), B($2\sin t$, $-2\cos t$) and C($3r-n$, r^2-n-1) be the vertices of a triangle ABC, where t is a parameter. If $(3x-1)^2+(3y)^2=\alpha$, is the locus of the centroid of triangle ABC, then ' α ' equals.

- 1) 18 2) 8 3) 20 4) 6

Key: 3

$$\text{Sol: } \frac{n_{C_{r-1}}}{n_{C_r}} = \frac{28}{56} \Rightarrow 3r=n+1 \dots\dots(1)$$

$$\frac{n_{C_r}}{n_{C_{r+1}}} = \frac{56}{70} \Rightarrow 3r=4n-5 \dots\dots(2)$$

$$\text{From (1) and (2)} \Rightarrow n=8, r=3 \qquad (3x-1)^2 + (3y)^2 = 16+4=20 \Rightarrow \alpha=20$$

10. If $\int_{-\frac{\pi}{2}}^{\frac{\pi}{2}} \frac{96x^2 \cos^2 x}{1+e^x} dx = \pi(\alpha\pi^2 + \beta)$, $\alpha, \beta \in Z$, then $(\alpha + \beta)^2$ equals

- 1) 144 2) 100 3) 196 4) 64

Key: 2

$$\text{Sol: } I = \int_{-\frac{\pi}{2}}^{\frac{\pi}{2}} \frac{96x^2 \cos^2 x}{1+e^x} dx = \int_0^{\frac{\pi}{2}} 96x^2 \cos^2 x dx$$

$$= 48 \int_0^{\frac{\pi}{2}} x^2 (1 + \cos 2x) dx = 16 \left[\frac{\pi^2}{8} \right] + 48 \left[\frac{x^2 \sin 2x}{2} \Big|_0^{\frac{\pi}{2}} - \int_0^{\frac{\pi}{2}} (2x) \left(\frac{\sin 2x}{2} \right) dx \right]$$

$$= 2\pi^2 + 48(0 - 0) - 48 \int_0^{\frac{\pi}{2}} x^2 \cos 2x dx$$

$$= 2\pi^3 - 48 \left[\left(\frac{\pi}{2} \right) \times \frac{1}{2} \right] + 48 \int_0^{\frac{\pi}{2}} \frac{\cos 2x}{2} dx$$

$$= 2\pi^2 - 12\pi + (0 - 0) = \pi [2\pi^2 - 12] \qquad = \pi [\alpha\pi^2 + \beta]$$

$$\Rightarrow \alpha = 2, \beta = -12 \qquad \Rightarrow (\alpha + \beta)^2 = (2 - 12)^2 = 100$$

11. The sum of the square of all the roots of the equation $x^2 + |2x - 3| - 4 = 0$ is

- 1) $6(2-\sqrt{2})$ 2) $3(3-\sqrt{2})$ 3) $6(3-\sqrt{2})$ 4) $3(2-\sqrt{2})$

Key: 1

Sol: $2x - 3 \geq 0 \Rightarrow x^2 + 2x - 7 = 0$

$$x = \frac{-2 \pm \sqrt{4 + 28}}{2} = -1 \pm \sqrt{2}$$

$$\therefore -1 - 2\sqrt{2} < \frac{3}{2} \quad \therefore x_1 = -1 + 2\sqrt{2}$$

$$2x - 3 < 0 \Rightarrow x_2 = 1 - \sqrt{2}$$

$$\therefore x_1^2 + x_2^2 = 12 - 6\sqrt{2} = 6(2 - \sqrt{2})$$

12. Let for some function $y=f(x)$, $\int_0^x tf(t)dt = x^2f(x)$, $x > 0$ and $f(2) = 3$ then $f(6)$ is equal to

- 1) 1 2) 3 3) 2 4) 6

Key: 1

Sol: $\int_0^x tf(t)dt = x^2f(x)$

Differentiating both sides w.r.t 'x'

$$xf(x) = x^2f'(x) + 2xf(x)$$

$$\frac{x^2 dy}{dx} + xy = 0$$

$$\frac{dy}{y} = \frac{-dx}{x}$$

$$\ln y + \ln x = \ln c$$

$$Yx = c$$

$$As f(2) = 3$$

$$6 = c$$

$$\therefore yx = 6$$

$$\therefore \text{Put } x = 6$$

$$y(6) = 6 \quad y = 1$$

13. Let ABCD be a trapezium whose vertices lie on the parabola $y^2=4x$. Let the sides AD and BC of the trapezium be parallel to y-axis. If the diagonal AC is of length $\frac{25}{4}$ and it passes through the point (1,0), then the area of ABCD is

- 1) $\frac{125}{8}$ 2) $\frac{75}{4}$ 3) $\frac{25}{2}$ 4) $\frac{75}{8}$

Key: 2

Sol: $a\left(t+\frac{1}{t}\right)^2 = \frac{25}{4}$ $t+\frac{1}{t} = \frac{5}{2} = 2 + \frac{1}{2}$ $t=2, \frac{1}{2}$

$A = \left(\frac{1}{4}, 1\right), B = (4, 4)$ $C = (4, -4), D = \left(\frac{1}{4}, -1\right)$

Area = $\frac{1}{2}(2+8)\left(4 - \frac{1}{4}\right) = \frac{75}{4}$

14. Three defective oranges are accidentally mixed with seven good ones and on looking at them, it is not possible to differentiate between them. Two oranges are drawn at random from the lot. If 'x' denote the number of defective oranges, then the variance of 'x' is

- 1) $\frac{14}{25}$ 2) $\frac{28}{75}$ 3) $\frac{26}{75}$ 4) $\frac{18}{25}$

Key: 2

Sol: 3 oranges 7 good oranges 2 oranges

x	0	1	2
$P(X=x_i)$	$\frac{{}^7C_2}{{}^{10}C_2}$	$\frac{{}^7C_1 \times {}^3C_1}{{}^{10}C_2}$	$\frac{{}^3C_2 \times {}^7C_0}{{}^{10}C_2}$

x	0	1	2
$P(X=x_i)$	$\frac{7}{15}$	$\frac{7}{15}$	$\frac{1}{15}$

$$\mu = \frac{9}{15} = \frac{3}{5}$$

$$\sigma^2 = \sum X_i P(x_i) - \mu^2$$

$$\sigma^2 = \frac{11}{15} - \frac{9}{25} = \frac{28}{75}$$

15. Let $\langle a_n \rangle$ be a sequence such that $a_0=0$, $a_1 = \frac{1}{2}$ and $2a_{n+2} = 5a_{n+1} - 3a_n$,

$n=0,1,2,3,\dots$. Then $\sum_{k=1}^{100} a_k$ is equal to

- 1) $3a_{99} + 100$ 2) $3a_{100} - 100$ 3) $3a_{100} + 100$ 4) $3a_{99} - 100$

Key: 2

Sol: $2a_{n+2} = 5a_{n+1} - 3a_n \Rightarrow 2x^2 - 5x + 3 = 0 \Rightarrow x = 1, 3/2$

$$\therefore a_n = A \cdot 1^n + B \cdot \left(\frac{3}{2}\right)^n$$

$$n=0 \Rightarrow a_0 = A + B \Rightarrow A + B = 0$$

$$n=1 \Rightarrow \frac{1}{2} = A + \frac{3}{2}B \Rightarrow B = 1 \qquad \therefore a_n = -1 + \left(\frac{3}{2}\right)^n$$

$$\sum_{k=1}^{100} a_k = \sum_{k=1}^{100} \left[(-1) + \left(\frac{3}{2}\right)^k \right] = -100 + \frac{\frac{3}{2} \left(\left(\frac{3}{2}\right)^{100} - 1 \right)}{\frac{3}{2} - 1}$$

$$= 3a_{100} - 100$$

16. Let $f : \mathbb{R} \rightarrow \mathbb{R}$ be a function defined by $f(x) = (2+3a)x^2 + \left(\frac{a+2}{a-1}\right)x + b$, $a \neq 1$. If

$f(x+y) = f(x) + f(y) + 1 - \frac{2}{7}xy$. Then the value of $28 \sum_{i=1}^5 |f(i)|$ is

- 1) 545 2) 735 3) 715 4) 675

Key: 4

Sol: $f(x+y) = f(x) + f(y) + 1 - \frac{2}{7}xy$

$$x=y=0 \Rightarrow f(0) = -1$$

$$\therefore f(0) = 0 + 0 + b = -1 \Rightarrow b = -1$$

$$\text{Put } y = -x \Rightarrow f(0) = f(x) + f(-x) + 1 + \frac{2}{7}x^2$$

$$\Rightarrow -1 = 2(3a+2)x^2 + 2b + 1 + \frac{2}{7}x^2$$

$$\Rightarrow -1 = \left(2(3a+2) + \frac{2}{7}\right)x^2 + 2b + 1$$

$$\Rightarrow -1 = \left(6a+4 + \frac{2}{7}\right)x^2 + 2(-1) + 1$$

$$\Rightarrow 6a+4 + \frac{2}{7} = 0 \Rightarrow a = -\frac{5}{7}$$

$$\therefore f(x) = \frac{1}{7}x^2 - \frac{3}{4}x - 1 \Rightarrow |f(x)| = \frac{1}{28}|4x^2 + 21x + 28|$$

$$\text{Now } 28 \sum_{i=1}^5 |f(i)| = 28|f(1) + f(2) + \dots + f(5)|$$

$$= 28 \cdot \frac{1}{28} \cdot 675 = 675$$

17. Let 'o' be the origin, the point 'A' be $z_1 = \sqrt{3} + 2\sqrt{2}i$, then point B (z_2) be such that

$$\sqrt{3}|z_2| = |z_1| \text{ and } \arg(z_2) = \arg(z_1) + \frac{\pi}{6} \text{ then}$$

1) ABO is an obtuse angled isosceles triangle

2) area of triangle ABO is $\frac{11}{4}$

3) area of triangle ABO is $\frac{11}{\sqrt{3}}$

4) ABO is a scalene triangle

Key: 1

$$\text{Sol: } z_2 = \left| \frac{z_2}{z_1} \right| \cdot z_1 e^{i\left(\frac{\pi}{6}\right)} \quad [\text{Rotation concept}]$$

$$\Rightarrow z_2 = \frac{1}{\sqrt{3}} \frac{(\sqrt{3} + 2\sqrt{2}i)(\sqrt{3} + i)}{2} \Rightarrow z_2 = \frac{(3 - 2\sqrt{2}) + i(2\sqrt{6} + \sqrt{3})}{2\sqrt{3}}$$

$$\text{Now } z_1 - z_2 = \frac{(3 + 2\sqrt{2}) + i(2\sqrt{6} - \sqrt{3})}{2\sqrt{3}}$$

$$\therefore |z_1 - z_2| = |z_2| \Rightarrow \Delta \text{ is isosceles with angles } \frac{\pi}{6}, \frac{\pi}{6}, \frac{2\pi}{3}$$

18. Let A (x,y,z) be a point in xy-plane which is equidistant from three points (0,3,2), (2,0,3) and (0,0,1). Let B=(1,4,-1) and C(2,0,-2). Then among the Statements
- Statement-1: ΔABC is an isosceles right angled triangle, and

Statement:2: The area of ΔABC is $\frac{9\sqrt{2}}{2}$

- 1) Both are true 2) Only S_1 is true 3) Both are false 4) Only S_2 is true

Key: 2

Sol: A(x,y,z) lies on xy plane $\therefore z = 0 \Rightarrow A = (x,y,0)$

Let P (0,3,2), Q (2,0,3), R(0,0,1)

$$AP=AQ=AR$$

$$x^2+(y-3)^2+4=(x-2)^2+y^2+9=x^2+y^2+1 \quad \Rightarrow 4x=12 \Rightarrow x=3$$

$$6y=12$$

$$y=2$$

$$\therefore A(3,2,0), B(1,4,-1), C(2,0,-2)$$

$$\therefore AB=\sqrt{4+4+1}=\sqrt{69}$$

$$BC=\sqrt{1+16+1}=\sqrt{18}$$

$$AC=\sqrt{1+4+4}=\sqrt{9}$$

$$\therefore AB=AC, AB^2+AC^2=BC^2$$

$$\Delta ABC = \begin{vmatrix} i & j & k \\ 2 & -2 & 1 \\ 1 & 2 & 2 \end{vmatrix} = i(-6) - j(3) + k(6)$$

$$\frac{1}{2} \sqrt{36+9+36} = \frac{9}{2}$$

19. The sum of all local minimum values at the function

$$f(x) = \begin{cases} 1-2x & , \quad x < -1 \\ \frac{1}{3}(7+2|x|) & , \quad -1 \leq x \leq 2 \\ \frac{11}{18}(x-4)(x-5) & , \quad x > 2 \end{cases} \text{ is}$$

1) $\frac{157}{72}$

2) $\frac{171}{72}$

3) $\frac{167}{72}$

4) $\frac{131}{72}$

Key: 1

$$\text{Sol: } f(x) = \begin{cases} 1-2x & x < -1 \\ \frac{1}{3}(7+2|x|) & -1 \leq x \leq 2 \\ \frac{11}{18}(x-4)(x-5) & x > 2 \end{cases}$$

$$f(x) = \begin{cases} 1-2x & x < -1 \\ \frac{1}{3}(7-2x) & -1 \leq x < 0 \\ \frac{7}{3} & x = 0 \\ \frac{1}{3}(7+2x) & 0 < x \leq 2 \\ \frac{11}{18}(x-4)(x-5) & x > 2 \end{cases}$$

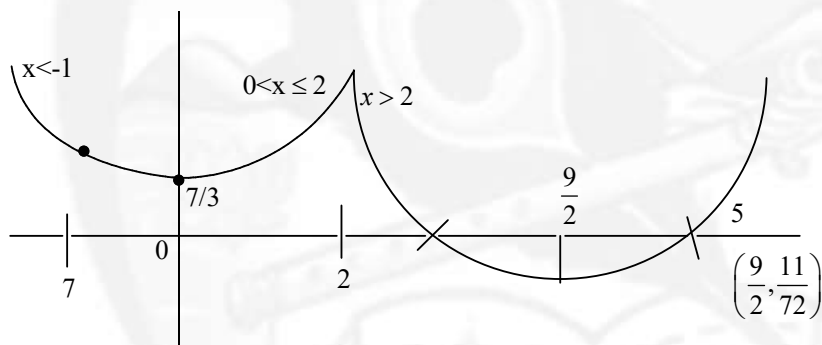

Local minima at $x=0$, $x=\frac{9}{2}$

$$\text{Sum} = f(0) + f\left(\frac{9}{2}\right) = \frac{7}{3} - \frac{4}{72} = \frac{157}{72}$$

20. The area (in sq. units) of the region $\{(x, y); 0 \leq y \leq 2|x|+1, 0 \leq y \leq x^2+1, |x| \leq 3\}$ is

- 1) $\frac{64}{3}$ 2) $\frac{80}{3}$ 3) $\frac{32}{3}$ 4) $\frac{17}{3}$

Key: 1

$$\text{Sol: } \text{R.A} = 2 \left[\int_0^2 (x^2+1) dx + \int_2^3 (2x+1) dx \right] = \frac{64}{3}$$

(NUMERICAL VALUE TYPE)

This section contains 10 questions. Each question is numerical value type. For each question, enter the correct numerical value (in decimal notation, truncated/rounded-off to second decimal place. (e.g. 6.25, 7.00, 0.33, 30, 30.27, 127.30). Attempt any five questions out of 10.

Marking scheme: +4 for correct answer, 0 if not attempted and 0 in all other cases.

21. Let $E_1 : \frac{x^2}{9} + \frac{y^2}{4} = 1$ be an ellipse. Ellipses E_i s are constructed such that their centres and eccentricities are same as that of E_1 and the length of minor axis of E_i and the length of major axis of E_{i+1} ($i \geq 1$). If A_i is the area of the ellipse E_i then $\frac{5}{\pi} \left(\sum_{i=1}^{\infty} A_i \right)$ is equal to _____

Key: 54

$$\begin{aligned} \text{Sol: } a_{i+1} &= b_i \quad e_i = e_{i+1} \Rightarrow \frac{b_i^2}{a_i^2} = \frac{b_{i+1}^2}{a_{i+1}^2} = \frac{b_{i+1}^2}{b_i^2} \\ \Rightarrow b_{i+1} &= \frac{b_i^2}{a_i} \quad A_{i+1} = \pi a_{i+1} b_{i+1} \\ &= \pi b_i a_i \frac{b_i^2}{a_i} = \pi b_i a_i \left(\frac{b_i}{a_i} \right)^2 = A_i \left(\frac{b_i}{a_i} \right)^2 \\ A_{i+1} &= A_i (1 - e_i^2) = A_i \cdot \frac{4}{9} \\ \therefore \sum A_i &= \frac{6\pi}{1 - \frac{4}{9}} = \frac{54\pi}{5} \\ \frac{5}{\pi} \left(\sum_{i=1}^{\infty} A_i \right) &= \frac{5}{\pi} \frac{54\pi}{5} = 54 \end{aligned}$$

22. Let 'M' denote the set of all real matrices of order 3 x 3 and let $s = \{-3, -2, -1, 1, 2\}$. let

$$S_1 = \left\{ A = [a_{ij}] \in M : A = A^T \text{ and } a_{ij} \in s, \forall i, j \right\}$$

$$S_2 = \left\{ A = [a_{ij}] \in M : A = -A^T \text{ and } a_{ij} \in S, \forall i, j \right\}$$

$$S_3 = \left\{ A = [a_{ij}] \in M : a_{11} + a_{22} + a_{33} = 0 \text{ \& } a_{ij} \in S, \forall i, j \right\}. \text{ If } n(S_1 \cup S_2 \cup S_3) = 125\alpha \text{ then}$$

Key: 1613

Sol: $S = \{-3, -2, -1, 1, 2\}$

$$S_1 = A = A^T \begin{bmatrix} 5 & 5 & 5 \\ - & 5 & 5 \\ - & - & 5 \end{bmatrix}$$

$$n(s_1) = 5^6 \quad s_2 = A^T = -A \quad 0 \notin s \therefore n(s_2) = 0$$

$$s_3 : a_{11} + a_{22} + a_{33} = 0 \quad \therefore \begin{bmatrix} -3 & & \\ & 2 & \\ & & 1 \end{bmatrix} 3!$$

$$a_{i+1} = bi \quad e_i = e_{i+1} \begin{bmatrix} 2 & & \\ & -1 & \\ & & -1 \end{bmatrix} \frac{3}{12}$$

$$n(s_3) = 12 \cdot 5^6, n(s_n \cap s_3) = (3! + 3 + 3) \cdot 5^3$$

$$\therefore n(s_1 \cup s_2 \cup s_3) = 5^6 + 12 \cdot 5^6 - 12 \cdot 5^3$$

$$= 5^3 (5^3 + 12 \cdot 5^3 - 12) = 125(125 + 1500 - 12)$$

$$= 125(1613) \quad \therefore \alpha = 1613$$

23. Let $f(x) = \begin{cases} 3x, & x < 0 \\ \min\{1 + x + [x], x + 2[x]\}, & 0 \leq x \leq 2 \text{ where } [.] \text{ denotes greatest integer} \\ 5, & x > 2 \end{cases}$

function. If ' α ' and ' β ' are the number of points, where ' f ' is not continuous and is not differentiable, respectively, then $\alpha + \beta$ equals ____

Key: 5

$$\text{Sol: } f(x) = \begin{cases} 3x & x < 0 \\ x & 0 \leq x < 1 \\ x + 2 & 1 \leq x < 2 \\ 5 & x = 2 \\ 5 & x > 2 \end{cases}$$

$$\alpha = 2$$

$$\beta = 3$$

$$\therefore \alpha + \beta = 5$$

24. If $\alpha = 1 + \sum_{r=1}^6 (-3)^{r-1} {}^{12}C_{2r-1}$. Then the distance of the point $(12, \sqrt{3})$ from the line $\alpha x - \sqrt{3}y + 1 = 0$ is _____

Key: 5

Sol:
$$\begin{aligned} \alpha &= 1 + \sum_{r=1}^6 (-3)^{r-1} {}^{12}C_{2r-1} \\ &= 1 + \sum_{r=1}^6 (-1)^{r-1} \frac{3^r}{3} {}^{12}C_{2r-1} \\ &= 1 + \sum_{r=1}^6 \frac{(-1)^{r-1}}{3} (\sqrt{3})^{2r-1} \sqrt{3} \cdot {}^{12}C_{2r-1} \\ &= 1 + \frac{1}{\sqrt{3}} \left[(\sqrt{3}) {}^{12}C_1 - (\sqrt{3})^3 {}^{12}C_3 + (\sqrt{3})^5 {}^{12}C_5 - (\sqrt{3})^7 {}^{12}C_7 + (\sqrt{3})^9 {}^{12}C_9 - (\sqrt{3})^{11} {}^{12}C_{11} \right] \\ &= 1 + \frac{1}{\sqrt{3}} \left[\frac{f(\sqrt{3}i) - f(\sqrt{3}i)}{2i} \right], f(x) = (1+x)^{12} = 1+0=1 \\ \therefore \frac{[12-3+1]}{\sqrt{1+3}} &= \frac{10}{2} = 5. \end{aligned}$$

25. Let $\vec{a} = \hat{i} + \hat{j} + \hat{k}$, $\vec{b} = 2\hat{i} + 2\hat{j} + \hat{k}$ and $\vec{d} = \vec{a} \times \vec{b}$. If \vec{c} is a vector such that $\vec{a} \cdot \vec{c} = |\vec{c}|$, $|\vec{c} - 2\vec{a}|^2 = 8$ & the angle between \vec{d} and \vec{c} is $\frac{\pi}{4}$, then $|10 - 3\vec{b} \cdot \vec{c}| + |\vec{d} \times \vec{c}|^2$ is equal to

Key: 6

Sol:
$$\begin{aligned} \vec{d} &= \vec{a} \times \vec{b} = -\hat{i} + \hat{j}, |\vec{c} - 2\vec{a}|^2 = 8 \Rightarrow |\vec{c}| = 2 \\ \vec{d} &= \vec{a} \times \vec{b} \Rightarrow \vec{d} \times \vec{c} = (\vec{a} \times \vec{b}) \times \vec{c} = (\vec{a} \cdot \vec{c}) \vec{b} - (\vec{b} \cdot \vec{c}) \vec{a} \\ \therefore |10 - 3(\vec{b} \cdot \vec{c})| + |\vec{d} \times \vec{c}|^2 &= 2 + 4 = 6 \end{aligned}$$

PHYSICS

Max Marks: 100

(SINGLE CORRECT ANSWER TYPE)

This section contains 20 multiple choice questions. Each question has 4 options (1), (2), (3) and (4) for its answer, out of which ONLY ONE option can be correct.

Marking scheme: +4 for correct answer, 0 if not attempted and -1 in all other cases.

26. Find the equivalent resistance between two ends of the following circuit

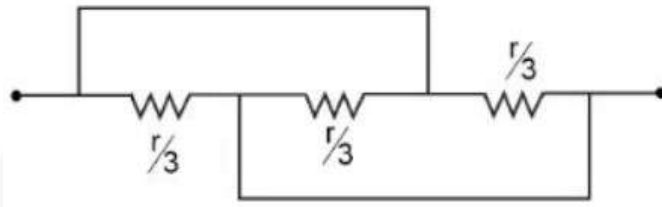

- 1) r 2) $\frac{r}{9}$ 3) $\frac{r}{3}$ 4) $\frac{r}{6}$

Key: 1

Sol:

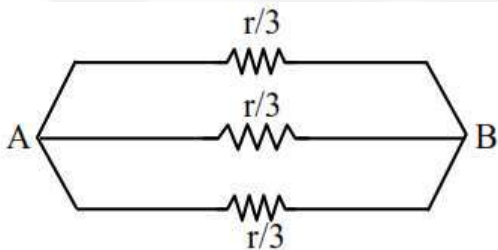

All are in parallel

$$R_{eq} = \frac{r/3}{3} = r/9$$

27. A proton of mass ' m_p ' has same energy as that of a photon of wavelength ' λ '. If the proton is moving at non-relativistic speed, then ratio of its de Broglie wavelength to the wavelength of photon is

- 1) $\frac{1}{c} \sqrt{\frac{2E}{m_p}}$ 2) $\frac{1}{c} \sqrt{\frac{E}{2m_p}}$ 3) $\frac{1}{2c} \sqrt{\frac{E}{m_p}}$ 4) $\frac{1}{c} \sqrt{\frac{E}{m_p}}$

Key: 2

Sol: E is missing in the question but considering E as energy, the solution will be

$$E_{\text{photon}} = \frac{hc}{\lambda} = E; E_{\text{proton}} = \frac{1}{2} m_p v^2 = E$$

$$\frac{\lambda_{\text{proton}}}{\lambda_{\text{photon}}} = \frac{h/p}{hc/E} = \frac{h/\sqrt{2m_p E}}{hc/E}$$

$$= \frac{E}{c\sqrt{2m_p E}}$$

$$\frac{\lambda_{\text{proton}}}{\lambda_{\text{photon}}} = \frac{1}{c} \sqrt{\frac{E}{2m_p}}$$

28. A hemispherical vessel is completely filled with a liquid of refractive index μ . A small coin is kept at the lowest point (O) of the vessel as shown in figure. The minimum value of the refractive index of the liquid so that a person can see the coin from point E (at the level of the vessel) is _____.

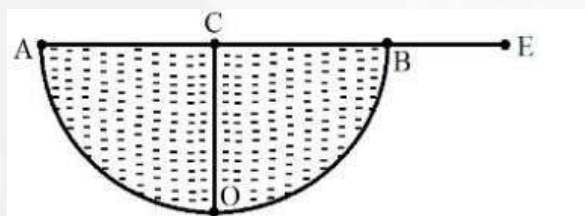

- 1) $\sqrt{2}$ 2) $\sqrt{3}$ 3) $\frac{\sqrt{3}}{2}$ 4) $\frac{3}{2}$

Key: 1

Sol:

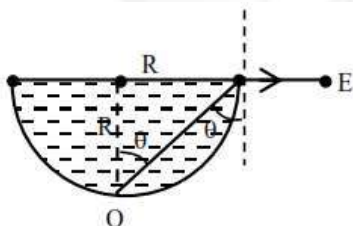

$$\sin c = \frac{1}{\mu}$$

for $\mu \rightarrow$ least, $c \rightarrow$ maximum

$$\theta = c = 45$$

$$\mu = \frac{1}{\sin 45} = \sqrt{2}$$

29. In the experiment for measurement of viscosity 'η' of given liquid with a ball having radius R, consider following statements.

- A. Graph between terminal velocity V and R will be a parabola
- B. The terminal velocities of different diameter balls are constant for a given liquid.
- C. Measurement of terminal velocity is dependent on the temperature.
- D. This experiment can be utilized to assess the density of a given liquid.
- E. If balls are dropped with some initial speed, the value of η will change.

Choose the correct answer from the options given below:

- 1) B, D and E only 2) A, C and D only 3) A, B and E only 4) C, D and E only

Key: 2

Sol:
$$V_r = \frac{2}{9} R^2 \frac{g}{\eta} (d - \rho)$$

30. For a particular ideal gas which of the following graphs represents the variation of mean squared velocity of the gas molecules with temperature ?

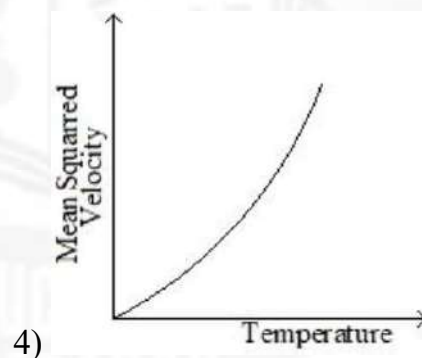
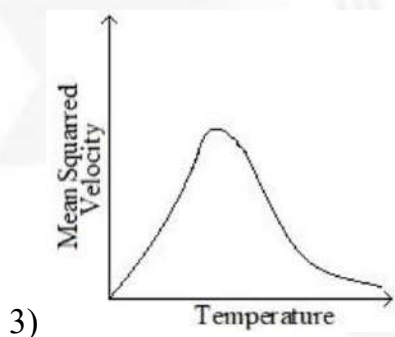
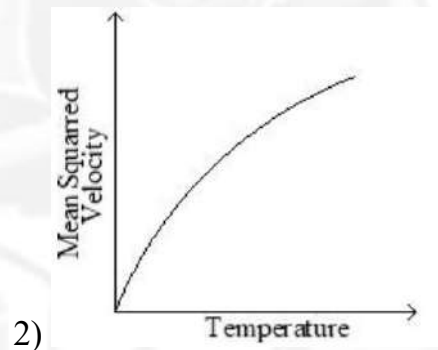
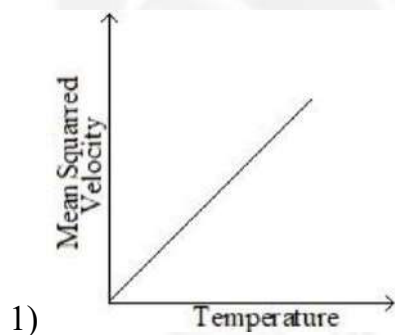

Key: 1

Sol:
$$V_{\text{rms}} = \sqrt{\frac{3RT}{M}}$$

$$V_{\text{rms}}^2 = 3RT / M$$

Key: 4

Sol:

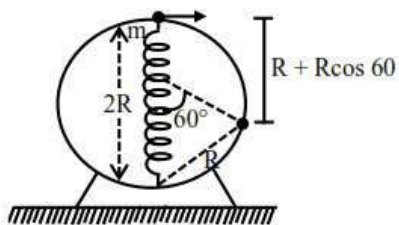

Work energy theorem

$$Mg(R + R \cos 60) + \frac{1}{2}k(R^2 - 0^2) = \frac{1}{2}mv^2$$

$$Mg \frac{3R}{2} + \frac{KR^2}{2} = \frac{1}{2}mv^2$$

$$V = \sqrt{3gr + \frac{KR^2}{m}}$$

33. A particle of mass 'm' and charge 'q' is fastened to one end 'A' of a massless string having equilibrium length l , whose other end is fixed at point 'O'. the whole system is placed on a frictionless horizontal plane and is initially at rest. If uniform electric field is switched on along the direction as shown in figure, then the speed of the particle when it crosses the x-axis is

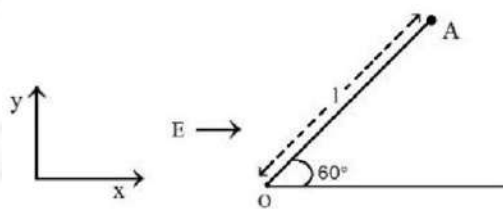

1) $\sqrt{\frac{qEl}{m}}$

2) $\sqrt{\frac{qEl}{4m}}$

3) $\sqrt{\frac{qEl}{2m}}$

4) $\sqrt{\frac{2qEl}{m}}$

Key: 1

Sol:

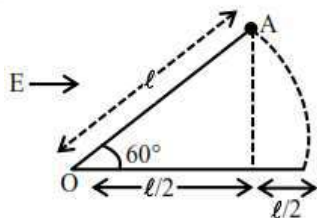

$$W_{all} = \Delta k \quad W_e = k_f - k_i$$

$$qE \frac{l}{2} = \frac{1}{2}mv^2 - 0$$

$$v = \sqrt{\frac{qEl}{m}}$$

34. The center of mass of thin rectangular plate (fig – x) with sides of length a and b , whose mass per unit area (σ) varies as $\sigma = \frac{\sigma_0 x}{ab}$ (where σ_0 is a constant), would be _____

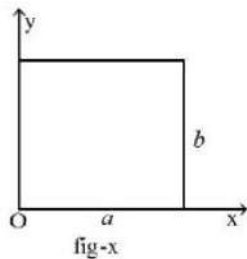

- 1) $\left(\frac{2}{3}a, \frac{b}{2}\right)$ 2) $\left(\frac{a}{2}, \frac{b}{2}\right)$ 3) $\left(\frac{2}{3}a, \frac{2}{3}b\right)$ 4) $\left(\frac{1}{3}a, \frac{b}{2}\right)$

Key: 1

Sol: σ is constant in y-direction

So, $y_{cm} = b/2$

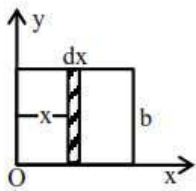

$$x_{cm} = \frac{\int_0^a x dm}{\int_0^a dm} = \frac{\int_0^a x \frac{\sigma_0 x}{ab} b dx}{\int_0^a \frac{\sigma_0 x}{ab} b dx}$$

35. A wire of resistance R is bent into an equilateral triangle and an identical wire is bent into a square. The ratio of resistance between the two end points of an edge of the triangle to that of the square is

- 1) $8/9$ 2) $32/27$ 3) $9/8$ 4) $27/32$

Key: 2

$$R = \frac{\rho \ell}{A}$$

So, $R \propto \ell$

Side length of triangle is $1/3$ of total length.

Sol: $R = \frac{\rho \ell}{A}$

So, $R \propto l$

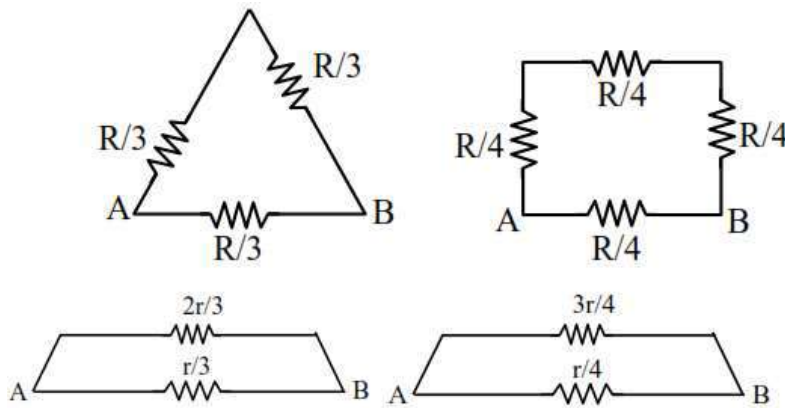

$$\frac{(R_{eq})_1}{(R_{eq})_2} = \frac{2r/9}{3r/16} = \frac{32}{27}$$

36. Given below are two statements: one is labelled as **Assertion A** and the other is labelled as **Reason R**

Assertion A: A sound wave has higher speed in solids than gases.

Reason R: Gases have higher value of Bulk modulus than solids.

In the light of the above statements, choose the correct answer from the options given below

- 1) Both **A** and **R** are true but **R** is NOT the correct explanation of **A**
- 2) **A** is true but **R** is false.
- 3) **A** is false but **R** is true
- 4) Both **A** and **R** are true and **R** is the correct explanation of **A**

Key: 2

Sol: Solids have higher value of bulk modulus than gases.

37. Choose the correct nuclear process from the below options

[p: proton, n: neutron, e^- : electron, e^+ : positron, ν : neutrino, $\bar{\nu}$: antineutrino]

- 1) $n \rightarrow p + e^- + \nu$
- 2) $n \rightarrow p + e^+ + \nu$
- 3) $n \rightarrow p + e^+ + \bar{\nu}$
- 4) $n \rightarrow p + e^- + \bar{\nu}$

Key: 4

Sol: Theoretical equation for β^- decay

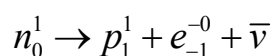

38. A thin prism P_1 with angle 4° made of glass having refractive index 1.54, is combined with another thin prism P_2 made of glass having refractive index 1.72 to get dispersion without deviation. The angle of the prism P_2 in degrees is
- 1) 1.5 2) 3 3) 4 4) $16/3$

Key: 2

Sol: $\delta_{net} = 0$

$$(\mu_1 - 1)A_1 - (\mu_2 - 1)A_2 = 0$$

$$(1.54 - 1)4 - (1.72 - 1)A_2 = 0$$

$$A_2 = 3^\circ$$

39. Consider following statements:

- A. Surface tension arises due to extra energy of the molecules at the interior as compared to the molecules at the surface, of a liquid.
- B. As the temperature of liquid rises, the coefficient of viscosity increases.
- C. As the temperature of gas increases, the coefficient of viscosity increases.
- D. The onset of turbulence is determined by Reynold's number.
- E. In a steady flow two stream lines never intersect.

Choose the correct answer from the options given below :

- 1) A, B, C only 2) C, D, E only 3) B, C, D only 4) A, D, E only

Key: 2

Sol: C, D, E only

40. Due to presence of an em-wave whose electric component is given by $E = 100 \sin(\omega t - kx) \text{ NC}^{-1}$, a cylinder of length 200 cm holds certain amount of em-energy inside it. If another cylinder of same length but half diameter than previous one holds same amount of em-energy, the magnitude of the electric field of the corresponding em-wave should be modified as

- 1) $400 \sin(\omega t - kx) \text{ NC}^{-1}$ 2) $50 \sin(\omega t - kx) \text{ NC}^{-1}$
- 3) $200 \sin(\omega t - kx) \text{ NC}^{-1}$ 4) $25 \sin(\omega t - kx) \text{ NC}^{-1}$

Key: 3

Sol: Energy density $\frac{1}{2} \epsilon_0 E^2 \times c$

$$\text{Energy} = \frac{1}{2} \epsilon_0 E^2 \times c \times \text{volume}$$

$$(\text{Energy})_1 = (\text{Energy})_2 \quad (\text{Given})$$

$$\frac{1}{2} \epsilon_0 E_1^2 c \pi R_1^2 \times L_1 = \frac{1}{2} \epsilon_0 E_2^2 c \pi R_2^2 \times L_2$$

$$E_1^2 R_1^2 = E_2^2 R_2^2$$

$$E_1 R_1 = E_2 R_2$$

$$100 \times R_1 = E_2 \times \frac{R_1}{2}$$

$$E_2 = 200 N / C$$

41. Given below are two statements : one is labelled as Assertion A and the other is labelled as Reason R

Assertion A : In a central force field, the work done is independent of the path chosen.

Reason R: Every force encountered in mechanics does not have an associated potential energy.

In the light of the above statements, choose the most appropriate answer from the options given below

- 1) Both A and R are true and R is the correct explanation of A
- 2) Both A and R are true but R is NOT the correct explanation of A
- 3) A is true but R is false
- 4) A is false but R is true

Key : 2

Sol. Both A and R are true but R is NOT the correct explanation of A

42. A carnot engine (E) is working between two temperatures 473K and 273K. In a new system two engines – engine E_1 works between 473K to 373K and engine E_2 works between 373K to 273K. If η_{12}, η_1 and η_2 are the efficiencies of the engines E, E_1 and E_2 , respectively, then

- 1) $\eta_{12} = \eta_1 + \eta_2$ 2) $\eta_{12} = \eta_1 \eta_2$ 3) $\eta_{12} < \eta_1 + \eta_2$ 4) $\eta_{12} \geq \eta_1 + \eta_2$

Key: 3

Sol. $\eta_{12} = 1 - \frac{273}{473} = \frac{200}{473} = 0.423$

$$\eta_1 = 1 - \frac{373}{473} = \frac{100}{473} = 0.211$$

$$\eta_2 = 1 - \frac{273}{373} = \frac{100}{373} = 0.268$$

43. Three infinitely long wires with linear charge density λ are placed along the x-axis, y-axis and z-axis respectively. Which of the following denotes an equipotential surface?

- 1) $(x+y)(y+z)(z+x) = \text{constant}$
 2) $xy + yz + zx = \text{constant}$
 3) $(x^2 + y^2)(y^2 + z^2)(z^2 + x^2) = \text{constant}$
 4) $xyz = \text{constant}$

Key : 3

Sol. $v = \int \vec{E} \cdot d\vec{r} = \int \frac{2k\lambda}{r} dr = 2k\lambda \ln r + c$

Net potential due to all wire

$$v = 2k\lambda \ln \sqrt{x^2 + y^2} + 2k\lambda \ln \sqrt{y^2 + z^2} + 2k\lambda \ln \sqrt{z^2 + x^2} + c$$

for $v=c$

$$\sqrt{(x^2 + y^2)(y^2 + z^2)(z^2 + x^2)} = c$$

$$\therefore (x^2 + y^2)(y^2 + z^2)(z^2 + x^2) = c$$

Where c=constant

44. Which of the following circuits has the same output as that of the given circuit?

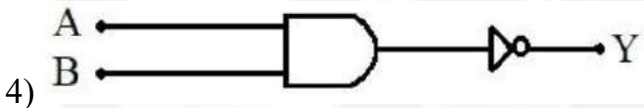
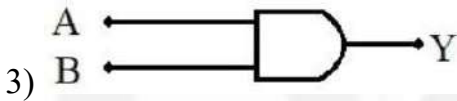
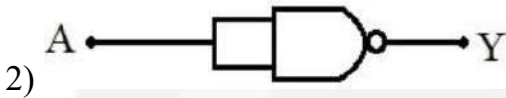
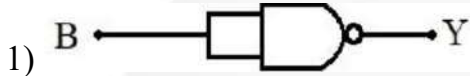
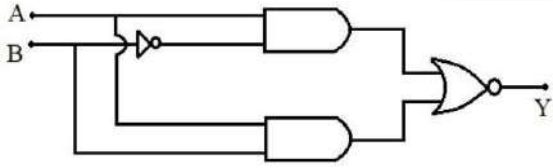

Key : 1

Sol.

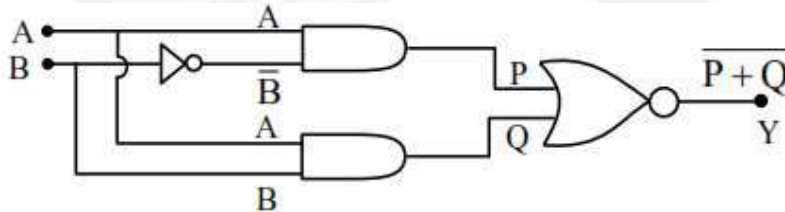

$$P = A\bar{B}$$

$$Q = AB$$

$$Y = \overline{P+Q} = \overline{A\bar{B} + AB} = \overline{A(B + \bar{B})} = \bar{A}$$

45. Consider a long thin conducting wire carrying a uniform current I. A particle having mass “M” and charge “q” is released at a distance “a” from the wire with a speed v_0 along the direction of current in the wire. The particle gets attracted to the wire due to magnetic force. The particle turns round when it is at distance x from the wire. The value of x is
 [μ_0 is vacuum permeability]

1) $a \left[1 - \frac{mv_0}{2q\mu_0 I} \right]$

2) $a \left[1 - \frac{mv}{q\mu_0 I} \right]$

3) $ae^{\frac{-4\pi mv_0}{q\mu_0 I}}$

4) $\frac{a}{2}$

Key : 3

Sol.

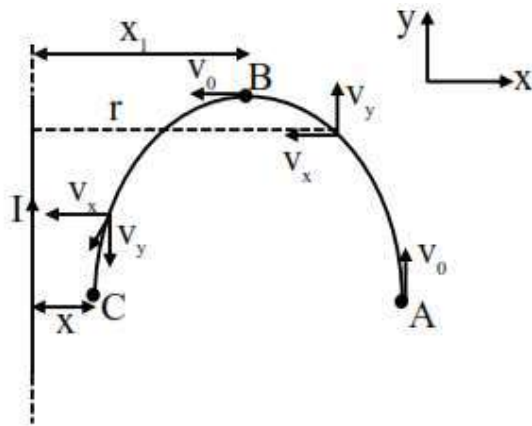
 $A \rightarrow B$

$$\vec{V} = v_x \hat{i} + v_y \hat{j}$$

$$\vec{B} = \frac{\mu_0 I}{2\pi r} (-\hat{k})$$

$$\vec{F} = q(\vec{v} \times \vec{B}) = \frac{\mu_0 I q}{2\pi r} (-v_x \hat{j} - v_y \hat{i})$$

$$a_x = -\frac{\mu_0 I q}{2\pi m} \cdot \frac{v_y}{r}$$

$$a_y = -\frac{\mu_0 I q}{2\pi m} \cdot \frac{v_x}{r}$$

$$\frac{v_x dv_x}{dr} = \frac{\mu_0 I q}{2\pi m} \frac{v_y}{r}$$

$$\frac{v_x dv_x}{dr} = \frac{\mu_0 I q}{2\pi m} \frac{v_y}{r}$$

$$\frac{v_x dv_x}{d_y} = \frac{\mu_0 I q}{2\pi m} \frac{dr}{r}$$

$$\int_0^{v_0} \frac{v_x dv_x}{\sqrt{v_0^2 - v_x^2}} = \frac{\mu_0 I q}{2\pi m} \int_0^{x_1} \frac{dr}{r}$$

$$\text{Let } z^2 = v_0^2 - v_x^2$$

$$2z dz = -2v_x dv_x$$

$$z dz = -v_x dv_x$$

$$\frac{v_x dv_x}{\sqrt{v_0^2 - v_x^2}} = \frac{-z dz}{z} = -dz$$

then integral becomes

$$-\int_{v_0}^0 dx = \frac{\mu_0 I q}{2\pi m} \ln \frac{x_1}{a}$$

$$v_0 = -\frac{\mu_0 I q}{2\pi m} \ln \frac{x_1}{a}$$

$$x_1 = a e^{\frac{2\pi m v_0}{\mu_0 I q}} \dots \dots (1)$$

For $B \rightarrow C$

$$\vec{v} = -v_x \hat{i} - v_y \hat{j}$$

$$\vec{B} = \frac{\mu_0 I}{2\pi r} (-\hat{k})$$

$$\vec{F} = q(\vec{v} \times \vec{B}) = \frac{\mu_0 I q}{2\pi r} (-v_x \hat{j} + v_y \hat{i})$$

$$a_x = +\frac{\mu_0 I q}{2\pi m} \frac{v_y}{r} \quad a_y = -\frac{\mu_0 I q}{2\pi m} \frac{v_x}{r}$$

$$\frac{v_x dv_x}{dr} = \frac{\mu_0 I q}{2\pi m} \frac{v_y}{r}$$

$$\int_{v_0}^0 \frac{v_x dv_x}{\sqrt{v_0^2 - v_x^2}} = \frac{\mu_0 I q}{2\pi m} \int_{x_1}^x \frac{dr}{r}$$

$$\frac{\mu_0 I q}{2\pi} \ln \frac{x}{x_1} = -\int_0^{v_0} dz = -v_0$$

$$x = x_1 e^{\frac{2\pi m v_0}{\mu_0 I q}} \dots (2)$$

From equation (1) and (2)

$$X = a e^{\frac{4\pi m v_0}{\mu_0 I q}}$$

(NUMERICAL VALUE TYPE)

This section contains 10 questions. Each question is numerical value type. For each question, enter the correct numerical value (in decimal notation, truncated/rounded-off to second decimal place. (e.g. 6.25, 7.00, 0.33, 30, 30.27, 127.30). Attempt any five questions out of 10.

Marking scheme: +4 for correct answer, 0 if not attempted and 0 in all other cases.

46. In a measurement, it is asked to find modulus of elasticity per unit torque applied on the system. The measured quantity has dimension of $[M^a L^b T^c]$. If $b=3$, the value of c is ____

Key. 3

$$\begin{aligned} \text{Sol. } \frac{\text{modulus of elasticity}}{\text{Torque}} &= \frac{[Force]}{[Area] \times [Force \times length]} \\ &= [L^{-3}] \end{aligned}$$

47. A tiny metallic rectangular sheet has length and breadth of 5 mm and 2.5 mm, respectively. Using a specially designed screw gauge which has pitch of 0.75 mm and 15 divisions in the circular scale, you are asked to find the area of the sheet. In this measurement, the maximum fractional error will be $\frac{x}{100}$ where x is ____

Key : 3

Sol.
$$\text{Least count} = \frac{\text{pitch length}}{\text{No. of division on circular scale}}$$

$$= \frac{0.75}{15} = 0.05 \text{ mm}$$

$$\frac{dA}{A} = \frac{dL}{L} + \frac{dW}{W}$$

$$\Rightarrow \frac{dA}{A} = \frac{1}{100} + \frac{2}{100} = \frac{3}{100}$$

$$\Rightarrow \frac{dA}{A} = \frac{1}{100} + \frac{2}{100} = \frac{3}{100}$$

48. Two iron solid discs of negligible thickness have radii R_1 and R_2 and moment of inertia I_1 and I_2 , respectively. For $R_2 = 2R_1$, the ratio of I_1 and I_2 would be $1/x$, where $x =$ ____

Key : 16

Sol.

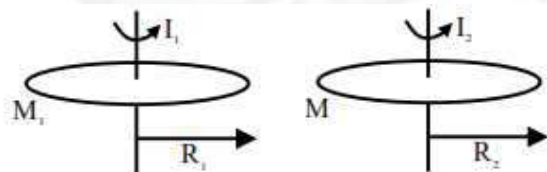

Given $R_2 = 2R_1$ $M_1 = \sigma \times \pi R_1^2 = \sigma \times \pi R_2^2 = M_2 = M_0$ $\frac{I_1}{I_2} = \frac{\frac{M_1 R_1^2}{2}}{\frac{M_2 R_2^2}{2}} = \frac{1}{4} \times \frac{1}{4} = \frac{1}{16}$

49. A double slit interference experiment performed with a light of wavelength 600nm forms an interference fringe pattern on a screen with 10th bright fringe having its centre at a distance of 10 mm from the central maximum. Distance of the centre of the same 10th bright fringe from the central maximum when the source of light is replaced by another source of wavelength 660nm would be _____ mm

Key: 11

Sol: $n_1 \lambda_1 = n_2 \lambda_2$.

50. The moment of inertia of a solid disc rotating along its diameter is 2.5 times higher than the moment of inertia of a ring rotating in similar way. The moment of inertia of a solid sphere which has same radius as the disc and rotating in similar way, is n times higher than the moment of inertia of the given ring. Here, $n = \underline{\hspace{2cm}}$.

Consider all the bodies have equal masses.

Key: 4

Sol:

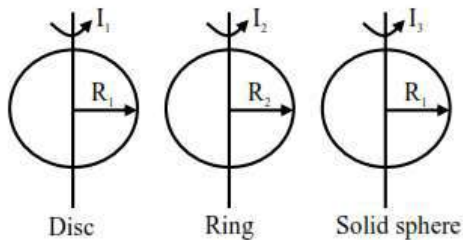

$$I_1 = \frac{MR_1^2}{4}, I_2 = \frac{MR_2^2}{2}, I_3 = \frac{2MR_1^2}{5}$$

According to problem

$$\frac{I_1}{I_2} = 2.5 \Rightarrow \frac{\frac{MR_1^2}{4}}{\frac{MR_2^2}{2}} = 2.5 \Rightarrow \frac{R_1^2}{R_2^2} = 5 \dots (1)$$

Now we are provided with information that

$$\frac{I_3}{I_2} = n$$

$$\Rightarrow \frac{\frac{2MR_1^2}{5}}{\frac{MR_2^2}{2}} = n \Rightarrow \frac{4R_1^2}{5R_2^2} = n \dots (2)$$

From Eq', (1) and (2)

$$\Rightarrow n = 4$$

C given

C-C α C α ($\alpha=x$)

$$K_a = \frac{C^2 \alpha^2}{C(1-\alpha)}$$

$$K_a = \frac{Cx \cdot x}{1-x}$$

$$K_a = \frac{[H^+]^x}{1-x}$$

$$\frac{K_a}{[H^+]} = \frac{x}{1-x}$$

$$\frac{[H^+]}{K_a} = \frac{1-x}{x}$$

On taking $-\log$

$$pH - pK_a = -\log\left(\frac{1-x}{x}\right)$$

$$pH - pK_a = \log\left(\frac{x}{1-x}\right)$$

54. Both acetaldehyde and acetone (individually) undergo which of the following reactions?

- | | |
|-------------------------|------------------------|
| A. Iodoform Reaction | B. Cannizzaro Reaction |
| C. Aldol Condensation | D. Tollen's Test |
| E. Clemmensen Reduction | |

Choose the correct answer from the options given below:

- | | |
|--------------------|--------------------|
| 1) C and E only | 2) B, C and D only |
| 3) A, B and D only | 4) A, C and E only |

Key: 4

Sol: Cannizzaro reaction is given by carbonyl compound with no α -H, Ketones do not give Tollen's Test

55. The incorrect decreasing order of atomic radii is

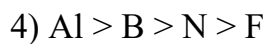
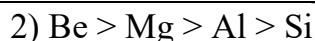
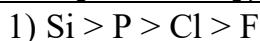

Key: 2

Sol: Incorrect order: $\text{Be} > \text{Mg} > \text{Al} > \text{Si}$ (Correct Order is $\text{Be} < \text{Si} < \text{Al} < \text{Mg}$)

56. Which of the following oxidation reactions are carried out by both $\text{K}_2\text{Cr}_2\text{O}_7$ and KMnO_4 in acidic medium?

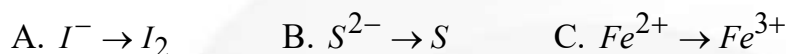

Choose the correct answer from the options given below:

1) C, D and E only

2) B, C and D only

3) A, D and E only

4) A, B and C only

Key: 4

Sol: In acidic medium KMnO_4 convert I^- to I_2 , $\text{S}^{2-} \rightarrow \text{S}$, $\text{Fe}^{2+} \rightarrow \text{Fe}^{3+}$ the rest of the reaction occurs in the alkaline or neutral medium.

57. Consider the following element In, Tl, Al, Pb, Sn and Ge.

The most stable oxidation states of elements with highest and lowest first ionization enthalpies, respectively, are

1) +4 and +1

2) +1 and +4

3) +2 and +3

4) +4 and +3

Key: 1

Sol: I.E order: $\text{Ge} > \text{Pb} > \text{Sn} > \text{Tl} > \text{Al} > \text{In}$
 $\begin{matrix} & 762 & 715 & 708 & 589 & 577 & 558 \end{matrix}$

Highest I.E: Ge (Stable oxidation state $\rightarrow +4$)Lowest I.E. : In (Stable oxidation state $\rightarrow +1$)

58. Given below are two statements:

Statement-I: D-glucose pentaacetate reacts with 2, 4 – dinitrophenylhydrazine

Statement-II: Starch, on heating with concentrated sulfuric acid at 100°C and 2 – 3 atmosphere pressure produces glucose.

In the light of the above statements, choose the correct answer from the options given below

- 1) Statement I is true but Statement II is false
- 2) Both Statement I and Statement II are false
- 3) Both Statement I and Statement II are true
- 4) Statement I is false but Statement II is true

Key: 4

Sol:

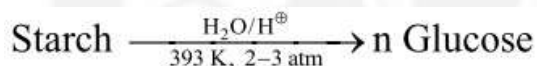
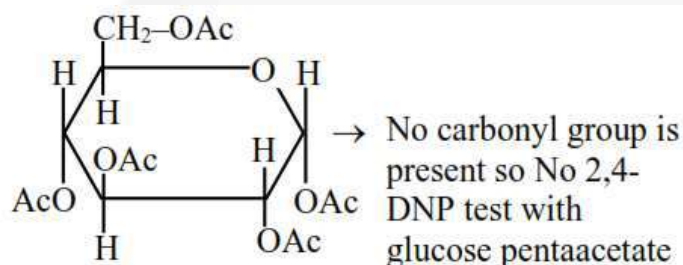

59. Match the List-I with List-II

List-I (Redox Reaction)		List-II (Type of Redox Reaction)	
A.	$\text{CH}_4(\text{g}) + 2\text{O}_2(\text{g}) \xrightarrow{\Delta} \text{CO}_2(\text{g}) + 2\text{H}_2\text{O}(\text{l})$	I.	Disproportionation reaction
B.	$2\text{NaH}(\text{s}) \xrightarrow{\Delta} 2\text{Na}(\text{s}) + \text{H}_2(\text{g})$	II.	Combination reaction
C.	$\text{V}_2\text{O}_5(\text{s}) + 5\text{Ca}(\text{s}) \xrightarrow{\Delta} 2\text{V}(\text{s}) + 5\text{CaO}(\text{s})$	III.	Decomposition reaction
D.	$2\text{H}_2\text{O}_2(\text{aq}) \xrightarrow{\Delta} 2\text{H}_2\text{O}(\text{l}) + \text{O}_2(\text{g})$	IV.	Displacement reaction.

Choose the correct answer from the options given below:

- 1) A – IV, B – I, C – II, D - III
- 2) A – II, B – III, C – I, D – IV
- 3) A – III, B – IV, C – I, D - II
- 4) A – II, B – III, C – IV, D - I

Key: 4

Sol:

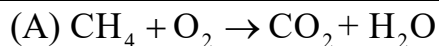

Combustion reaction

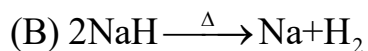

Thermal Decomposition reaction

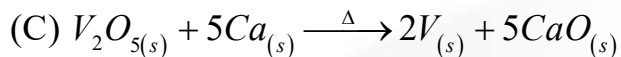

Displacement reaction

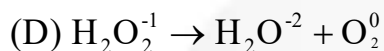

Disproportionation reaction

60. A molecule ("P") on treatment with acid undergoes rearrangement and gives ("Q"). ("Q") on ozonolysis followed by reflux under alkaline condition gives ("R"). The structure of ("R") is given below:

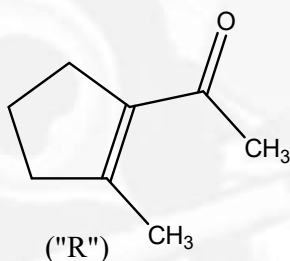

The structure of ("P") is

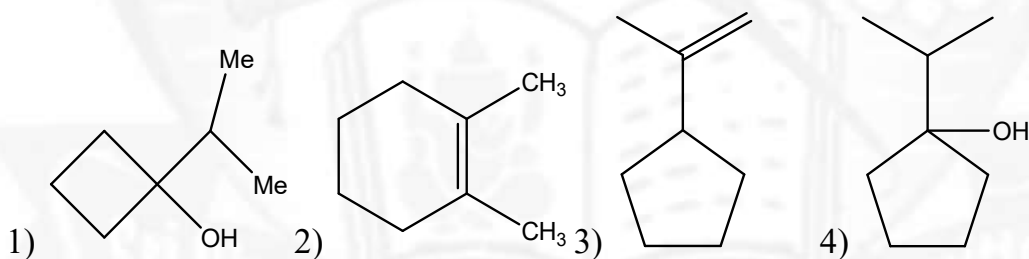

Key: 4

Sol:

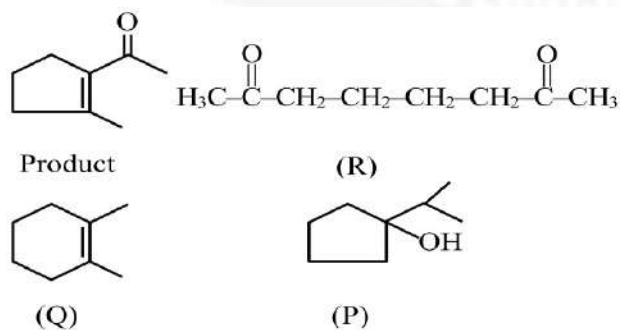

61. The correct order of stability of following carbocations is :

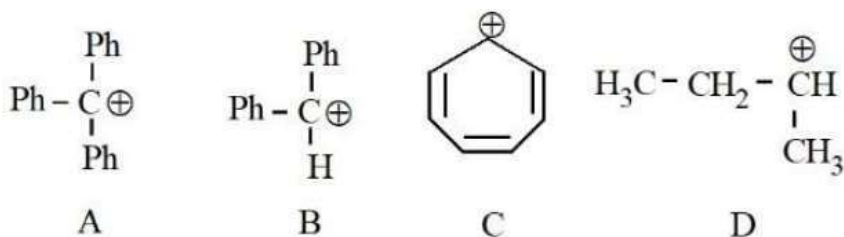

- 1) A > B > C > D 2) C > B > A > D 3) C > A > B > D 4) B > C > A > D

Key: 3

Sol: The correct stability order is

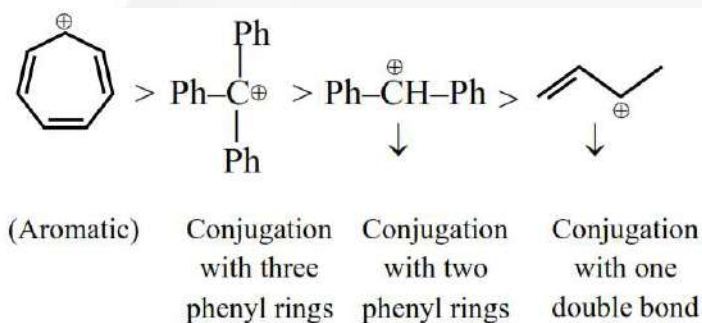

62. The products A and B in the following reactions, respectively are



- 1) $\text{CH}_3\text{-CH}_2\text{-CH}_2\text{-ONO}, \text{CH}_3\text{-CH}_2\text{-CH}_2\text{-CN}$
- 2) $\text{CH}_3\text{-CH}_2\text{-CH}_2\text{-NO}_2, \text{CH}_3\text{-CH}_2\text{-CH}_2\text{-NC}$
- 3) $\text{CH}_3\text{-CH}_2\text{-CH}_2\text{-ONO}, \text{CH}_3\text{-CH}_2\text{-CH}_2\text{-NC}$
- 4) $\text{CH}_3\text{-CH}_2\text{-CH}_2\text{-NO}_2, \text{CH}_3\text{-CH}_2\text{-CH}_2\text{-CN}$

Key: 2

Sol:

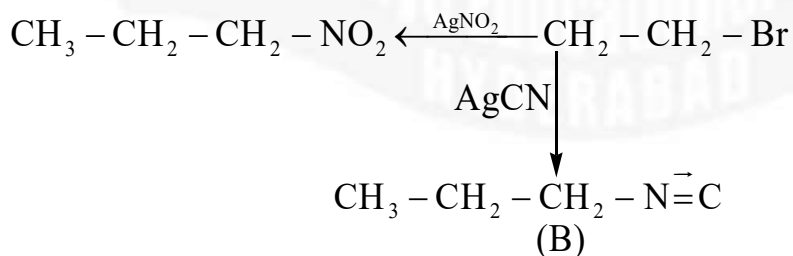

63. The metal ion whose electronic configuration is not affected by the nature of the ligand and which gives a violet colour in non-luminous flame under hot condition in borax bead test is

- 1) Mn^{2+} 2) Ni^{2+} 3) Ti^{3+} 4) Cr^{3+}

Key: 2

Sol: Colour of Borax bead in oxidising flame is violet for Ni^{+2}

64. Given below are two statements:

Statement-I: In the oxalic acid Vs $KMnO_4$ (in the presence of dil. H_2SO_4) titration the solution needs to be heated initially to $60^\circ C$, but no heating is required in Ferrous ammonium sulphate (FAS) Vs $KMnO_4$ titration (in the presence of dil H_2SO_4)

Statement-II: In oxalic acid Vs. $KMnO_4$ titration, the initial formation of $MnSO_4$ takes place at high temperature, which then acts as catalyst for further reaction. In the case of FAS vs. $KMnO_4$, heating oxidizes Fe^{2+} into Fe^{3+} by oxygen of air and error may be introduced in the experiment.

In the light of the above statements, choose the correct answer from the options given below:

- 1) Statement-I is true but Statement II is false
- 2) Both Statement-I and Statement II are false
- 3) Statement-I is false but Statement-II is true
- 4) Both Statement-I and Statement-II are true.

Key: 4

Sol: Mn^{+2} ion act as auto catalyst.

65. Ice and water are placed in a closed container at a pressure of 1atm and temperature 273.15K. If pressure of the system is increased 2 times, keeping temperature constant, then identify correct observation from following:

- 1) Liquid phase disappears completely
- 2) The amount of ice decreases
- 3) Volume of system increases
- 4) The solid phase (ice) disappears completely.

Key: 4

Sol:

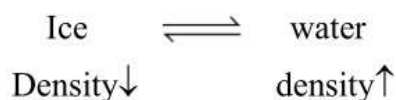

On increasing pressure equilibrium will shift forward & amount of the solid phase (ice) disappears completely

66.

$[A]_0 / \text{molL}^{-1}$	$t_{1/2} / \text{min}$
0.100	200
0.025	100

For a given reaction $R \rightarrow P$, $t_{1/2}$ is related to $[A]_0$ as given in table.

Given: $\log 2 = 0.30$

Which of the following is true?

- A. The order of the reaction is $\frac{1}{2}$.
- B. If $[A]_0$ is 1M, then $t_{1/2}$ is $200\sqrt{10}$ min
- C. The order of the reaction changes to 1 if the concentration of reagent changes from 0.100 M to 0.500 M.
- D. $t_{1/2}$ is 800 min for $[A]_0 = 1.6M$

Choose the correct answer from the options given below:

- 1) A, B and D only
- 2) C and D only
- 3) A and B only
- 4) A and C only

Key: 1

Sol: A) $\frac{(t_{1/2})_1}{(t_{1/2})_2} = \left(\frac{a_2}{a_1}\right)^{n-1}$ $\frac{200}{100} = \left(\frac{0.025}{0.1}\right)^{n-1}$ $n = \frac{1}{2}$

B) $\frac{200}{x} = \left(\frac{1}{10}\right)^{1/2}$ $x = 200\sqrt{10}$

D) $(t_{1/2})^\infty \frac{1}{a^{n-1}}$ $\frac{200}{x} = \left[\frac{1.6}{0.1}\right]^{\frac{1}{2}-1}$ $\frac{200}{x} = 16^{-\frac{1}{2}}$

$$x = 200 \times \sqrt{16} = 800 \text{ min}$$

67. In a multielectron atom, which of the following orbitals described by three quantum numbers will have same energy in absence of electric and magnetic fields?

- A. $n = 1, l = 0, m_l = 0$ B. $n = 2, l = 0, m_l = 0$
 C. $n = 2, l = 1, m_l = 1$ D. $n = 3, l = 2, m_l = 1$
 E. $n = 3, l = 2, m_l = 0$

Choose the correct answer from the options given below:

- 1) C and D only 2) A and B only 3) B and C only 4) D and E only

Key: 4

Sol: The $(n + 1)$ value determines the energy of the orbital. The lower the value of $(n + 1)$, the lower will be the energy of orbitals. If the value of $(n + 1)$ is the same for the two orbitals, then lower the value of n , the lower will be the energy of the orbital.

A) $n + 1 = 4$, B) $n + 1 = 3$, C) $n + 1 = 3$, D) $n + 1 = 5$, E) $n + 1 = 5$

Hence they both have the same energy.

68. What is the freezing point depression constant of a solvent, 50 g of which contain 1 g non volatile solute (molar mass 256 g mol^{-1}) and the decrease in freezing point is 0.40K ?

- 1) $4.43 \text{ K kg mol}^{-1}$ 2) $1.86 \text{ K kg mol}^{-1}$ 3) $5.12 \text{ K kg mol}^{-1}$ 4) $3.72 \text{ K kg mol}^{-1}$

Key: 3

Sol: Depression in freezing point $\Delta T_b = K_f \cdot m$

$$\text{Molality } m = \frac{1}{250} \times \frac{1000}{50} = 0.0781$$

$$K_f = \frac{\Delta T_b}{m} = 0.4/0.0781 = 5.12 \text{ K kg/mol}$$

69. Consider 'n' is the number of lone pair of electrons present in the equatorial position of the most stable structure of ClF_3 . The ions from the following with 'n' number of unpaired electrons are

- A. V^{3+} B. Ti^{3+} C. Cu^{2+} D. Ni^{2+} E. Ti^{2+}

Choose the correct answer from the given below:

- 1) B and C only 2) B and D only 3) A and C only 4) A, D and E only

Key: 4

Sol:

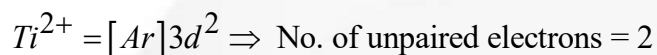
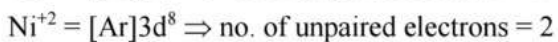
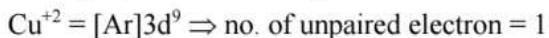
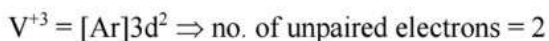
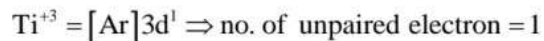
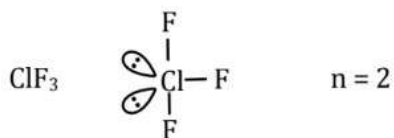

70. Given below are two statements:

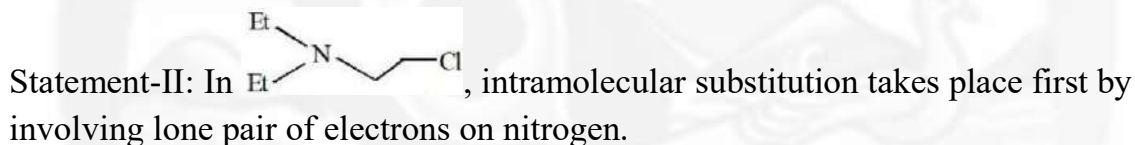
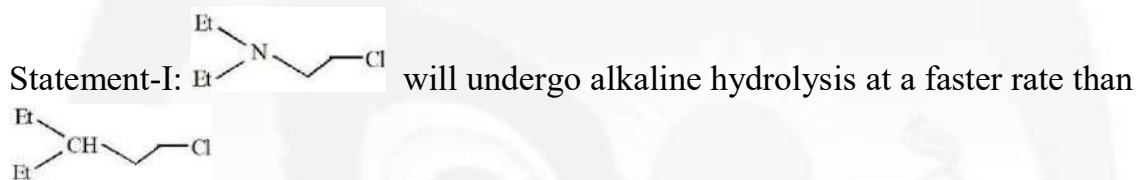

In the light of the above, statement, choose the most appropriate answer from the options given below:

- 1) Both Statement-I and Statement-II are correct
- 2) Statement-I is correct but Statement-II is incorrect
- 3) Both Statement-I and Statement-II are incorrect
- 4) Statement-I is incorrect but Statement-II is correct

Key: 1

Sol:

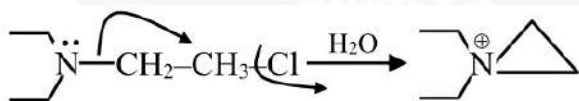

Due to NGP effect of nitrogen lone pair, rate of reaction increases

SECTION-II (NUMERICAL VALUE TYPE)

This section contains 5 Numerical Value Type Questions. The Answer should be within 0 to 9999. If the Answer is in Decimal then round off to the Nearest Integer value (Example i.e. If answer is above 10 and less than 10.5 round off is 10 and If answer is from 10.5 and less than 11 round off is 11).

Marking scheme: +4 for correct answer, 0 if not attempt and -1 in all other cases.

71. This formation enthalpies, ΔH_f^- for $H(g)$ and $O(g)$ are 220.0 and $250.0 \text{ kJ mol}^{-1}$, respectively, at 298.15K , and ΔH_f^- for $H_2O(g)$ is $-242.0 \text{ kJ mol}^{-1}$ at the same temperature. The average bond enthalpy of the O – H bond in water at 298.15 K is _____ kJ mol^{-1} (nearest integer)

Key: 466

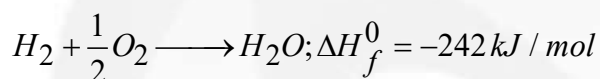
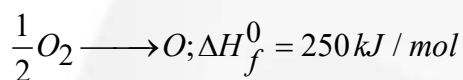
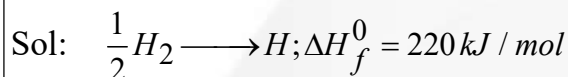

$$-242 = \left(\text{B.E. of } H_2 + \frac{1}{2} \text{ B.E. of } O_2 \right) - 2(\text{B.E. of O-H})$$

$$-242 = 440 + 250 - 2x$$

$$2x = 932$$

$$x = 466 \text{ kJ/mol}$$

72. Quantitative analysis of an organic compound (X) shows following % composition.
C: 14.5% Cl: 64.46% H: 1.8%

(Empirical formula mass of the compound (X) is _____ $\times 10^{-1}$)

(Given molar mass of g mol^{-1} of C: 12, H: 1, O: 16, Cl: 35.5)

Key: 165.5 or 1655×10^{-1}

Sol: % by mass of oxygen = $100 - (\text{Sum of \% by mass of C, H \& Cl}) = 19.34$

	C	H	Cl	O
% by mass	14.4	1.8	64.46	19.34
Mole	$\frac{14.4}{12}$	$\frac{1.8}{1}$	$\frac{64.46}{35.5}$	$\frac{19.34}{16}$
	1.2	1.8	1.815	1.20
	$\frac{1.2}{1.2}$	$\frac{1.8}{1.2}$	$\frac{1.815}{1.2}$	$\frac{1.2}{1.2}$
	1	1.5	1.5	1
	2	3	3	2

Empirical formula = $C_2H_3Cl_3O_2$

Empirical formula mass = 165.5

'x' is $165.5 \times 10^{-1} = 1655$

73. Consider the following sequence of reactions:

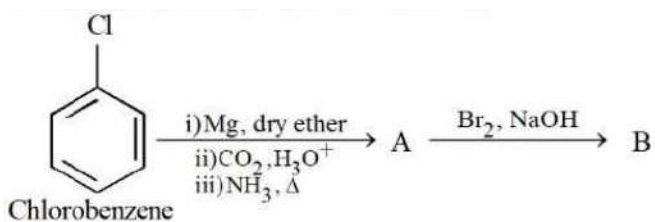

11.25 mg of chlorobenzene will produce $\text{---} \times 10^{-1} \text{ mg}$ of product B.

(Consider the reactions result in complete conversion)

[Given molar mass of C, H, O, N and Cl as 12, 1, 16, 14 and 35.5 g mol^{-1} respectively]

Key: 93

Sol:

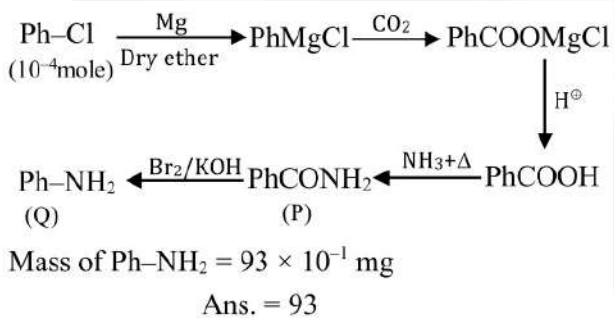

74. The molarity of a 70% (mass/mass) aqueous solution of a monobasic acid (X) is $\text{---} \times 10^{-1} \text{ M}$ (nearest integer)

[Given: Density of aqueous solution of (X) is 1.25 g mL^{-1}

Molar mass of the acid is 70 g mol^{-1}]

Key: 125

Sol:

$$W_{\text{solution}} = 100 \text{ g}$$

$$W_{\text{solute}} = 70 \text{ g}$$

$$V_{\text{solution}} = \frac{100}{1.25} \text{ ml} = 80 \text{ ml}$$

$$\text{Molarity} = \frac{\frac{70}{80}}{\frac{1000}{1000}}$$

$$\text{Molarity} = 12.5 = 125 \times 10^{-1}$$

Ans. 125

75. Given below is the plot of the molar conductivity vs $\sqrt{\text{concentration}}$ for KCl in aqueous solution

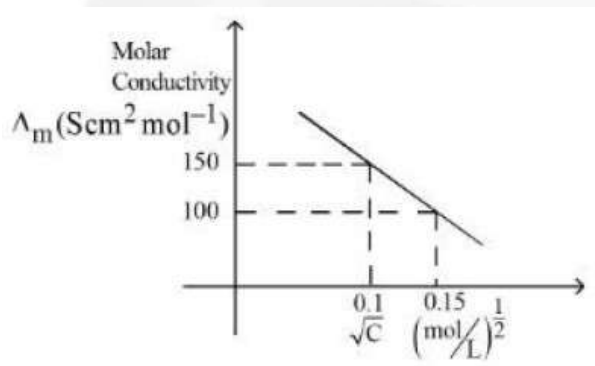

If, for the higher concentration of KCl solution, the resistance of the conductivity cell is 100Ω , then the resistance of the same cell with the dilute solution is 'x' Ω .

The value of x is _____ (Nearest integer)

Key: 150

Sol:

$$\Lambda_m = 150 \text{ S cm}^2 \text{ mole}^{-1}$$

$$C = 0.15 \text{ mol / Lit}$$

$$K = \Lambda_m C$$

$$= 150 \times 0.15 = 22.5 \text{ S cm}^{-1}$$

$$\text{Cell constant } (G^*) = R \times K = 22.5 \times 100 = 2250 \text{ cm}^{-1}$$

Conductivity of dilute solution

$$\Lambda_m = 100, C = 0.15$$

$$K = \Lambda_m \times C$$

$$= 15 \text{ Cm}^{-1}$$

$$R = \frac{G^*}{K} = \frac{2250}{15} = 150\Omega$$





Sri Chaitanya
Educational Institutions

Infinity
Learn



JEE MAIN 2024

300
300
MARKS



1
ALL INDIA RANK

EMPOWERING EVERY STUDENT TO BECOME EXTRAORDINARY

PROUDLY ACHIEVED 222 RANKS IN TOP 1000

K C BASAVA REDDY
APPL.No. 240310618179*

SEIZES 4 RANKS IN TOP 10 IN ALL-INDIA RANKS

300
300
MARKS



ALL INDIA RANK

3
RANK

THOTAMSETTY NIKILESH
APPL.No. 240310813888*

300
300
MARKS



ALL INDIA RANK

6
RANK

HIMANSHU THALOR
APPL.No. 240310580429*

300
300
MARKS



ALL INDIA RANK

9
RANK

REDDI ANIL
APPL.No.240310238514

SECURED 25 RANKS IN TOP 100 ALL INDIA OPEN CATEGORY

Sri Chaitanya - Nagpur
DLP Student

1 **9** **14** **20** **21** **22** **26** **28**

RANK **RANK** **RANK** **RANK** **RANK** **RANK** **RANK** **RANK**

G N NIRMALKUMAR APPL.No. 240310150036* REDDI ANIL APPL.No. 240310238514* K C BASAVA REDDY APPL.No. 240310618179* THOTAMSETTY NIKILESH APPL.No. 240310813888* A V TANISH REDDY APPL.No. 240310807613 HIMANSHU THALOR APPL.No. 240310580429* VEDANT SAINI APPL.No. 240310182830 P MEET VIKRAMBHAI APPL.No. 240310157524*

34 **40** **43** **46** **49** **52** **53** **57**

RANK **RANK** **RANK** **RANK** **RANK** **RANK** **RANK** **RANK**

SANVI JAIN APPL.No. 240310150036* VISHARAD SRIVASTAVA APPL.No. 240310046262* T JAYDEV REDDY APPL.No. 240310167365 ISHAAN GUPTA APPL.No. 240310100229* MAVURU JASWITH APPL.No. 240310542275* DORISALA SRINIVASA REDDY APPL.No. 240310682440* ARCHIT RAHUL PATIL APPL.No. 240310512311* KRISHNA AGRAWAL APPL.No. 240310285850*

60 **68** **70** **76** **92** **93** **95** **96** **98**

RANK **RANK** **RANK** **RANK** **RANK** **RANK** **RANK** **RANK** **RANK**

AYUSH GANGAL APPL.No. 240310270709 PALAGIRI SATHISH REDDY APPL.No. 240310905497 MD K GHOUSE MOHIUDDIN APPL.No. 240310176352 T V S SAI NAGA BHUSHAN APPL.No. 240310868568 M M PRUTHVI RAJ APPL.No. 240311084545 M SAI SIVA LOCHAN APPL.No. 240310866829* RAJDEEP MISHRA APPL.No. 240310285621* MANOJ SOHAN GAJULA APPL.No. 240310529661 KRISH NARSARIA APPL.No. 240310128286*



Below 100
All-India Open Category Ranks

25

Below 500
All-India Open Category Ranks

108

Below 1000
All-India Open Category Ranks

222

Below 100
All-India All Category Ranks

97

Below 1000
All Category Ranks

888

FOR OFFER ON JEE MAIN & JEE ADVANCED COURSES



SCAN THE QR CODE

TOTAL QUALIFIED RANKS FOR JEE ADVANCED-2024

21,987